

SWIVEL FLANGES

- Class 300 Flanges
- Class 600 Flanges
- Class 900 Flanges
- Class 1500 Flanges

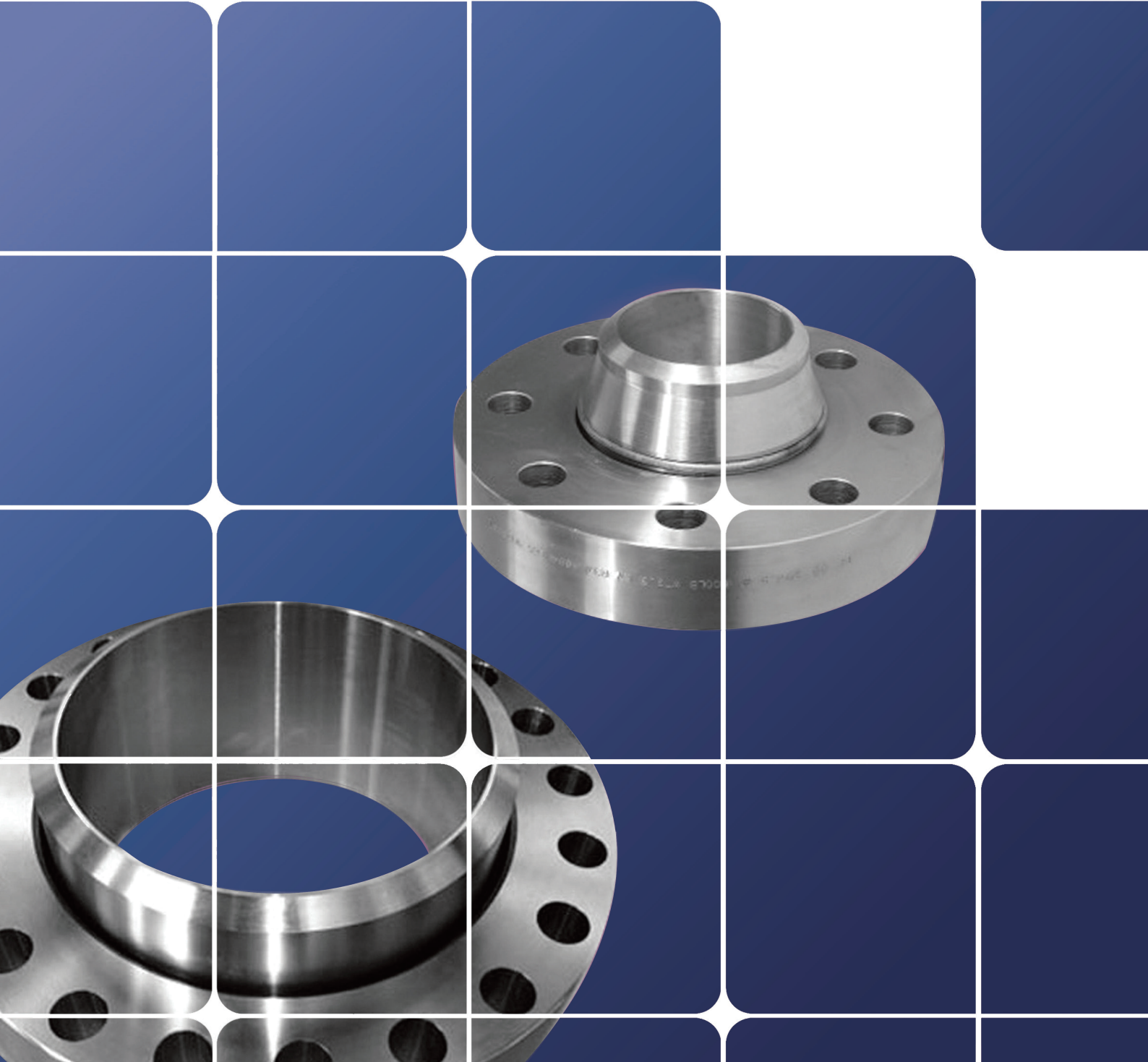

CLASS 300 FLANGES

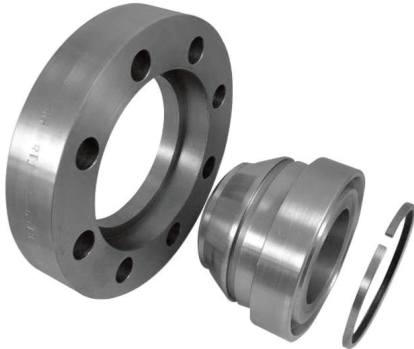
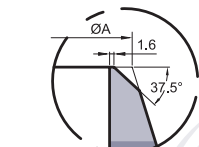
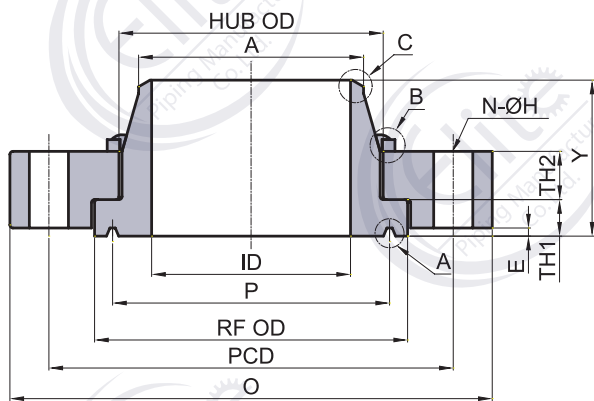

BEVEL FOR WALL THICKNESS W.T FROM 5mm TO 22.35mm INCLUSIVE
DETAIL OF "A"

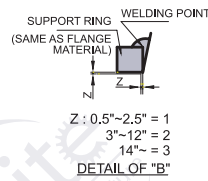

DETAIL OF "B"

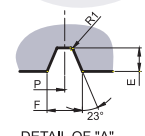

DETAIL OF "A"

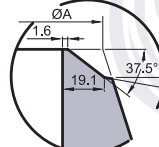

BEVEL FOR WALL THICKNESS W.T GREATER THAN 22.35mm
DETAIL OF "C" (26"~48")

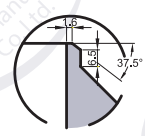

BEVEL FOR WALL THICKNESS W.T FROM 5mm TO 22.35mm INCLUSIVE
DETAIL OF "C" (1/2"~24")

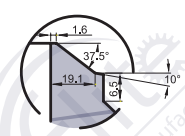

BEVEL FOR WALL THICKNESS W.T GREATER THAN 22.35mm
DETAIL OF "C" (1/2"~24")

Unit : mm

Nominal Dia. Of Flange (INCH)	Sectional Dimensions of flange															
	Outside Dia. Of Flange O (mm)	Inside Dia. Of Flange ID (mm)	Dia of Bolt Circle PCD (mm)	Dia. of Raised Face RF OD (mm)	P (mm)	TH1 (mm)	TH2 (mm)	Y (mm)	Dia. of Hub		F (mm)	E (mm)	Hole Dia H (mm)	Number of Bolt Holes N	RING NO	R1 (mm)
									A (mm)	HUB OD (mm)						
1/2	95.3	To be Customer.	66.5	50.8	34.14	8.9	8.9	56.4	21.3	38.1	7.14	5.56	15.9	4	R11	0.8
3/4	117.3		82.6	63.5	42.88	9.9	9.9	62	26.7	47.8	8.74	6.35	19.1	4	R13	0.8
1	124		88.9	69.9	50.8	11.2	11.2	66.8	33.4	53.8	8.74	6.35	19.1	4	R16	0.8
1 1/4	133.4		98.6	79.2	60.33	12.2	12.2	69.9	42.2	63.5	8.74	6.35	19.1	4	R18	0.8
1 1/2	155.4		114.3	90.4	68.28	13.5	13.5	73.2	48.3	69.9	8.74	6.35	22.2	4	R20	0.8
2	165.1		127	108	82.55	14.5	14.5	76.3	60.3	84.1	11.91	7.92	19.1	8	R23	0.8
2 1/2	190.5		149.4	127	101.6	16.8	16.8	82.6	73	100.1	11.91	7.92	22.2	8	R26	0.8
3	209.6		168.1	146.1	123.83	18.8	18.8	85.6	88.9	117.3	11.91	7.92	22.2	8	R31	0.8
3 1/2	228.6		184.2	158.8	131.78	19.8	19.8	87.4	101.6	133.4	11.91	7.92	22.2	8	R34	0.8
4	254		200.2	174.8	149.23	21.1	21.1	92.3	114.3	146.1	11.91	7.92	22.2	8	R37	0.8
5	279.4		235	209.6	180.98	23.4	23.4	105	141.3	177.8	11.91	7.92	22.2	8	R41	0.8
6	317.5		269.7	241.3	211.12	24.6	24.6	105	168.3	206.2	11.91	7.92	22.2	12	R45	0.8
8	381		330.2	301.8	269.88	28.7	29.2	117.7	219.1	273.8	11.91	7.92	25.4	12	R49	0.8
10	444.5		387.4	355.6	323.85	32.5	32.5	123.7	273.1	327.7	11.91	7.92	28.6	16	R53	0.8
12	520.7		450.9	412.8	381	36.3	35.6	136.4	323.9	384.8	11.91	7.92	31.8	16	R57	0.8
14	584.2		514.4	457.2	419.1	39.9	38.6	149.1	355.6	422.9	11.91	7.92	31.8	20	R61	0.8
16	647.7		571.5	508	469.9	43.7	41.7	152.5	406.4	473.7	11.91	7.92	34.9	20	R65	0.8
18	711.2		628.7	574.5	533.4	47.5	44.7	165.2	457.2	537.2	11.91	7.92	34.9	24	R69	0.8
20	774.7		685.8	635	584.2	51.1	47.8	170.1	508	588	13.49	9.53	34.9	24	R73	1.5
22	838.2		743	685.8	635	54.9	50.8	174.7	558.8	638.8	15.09	11.13	41.3	24	R81	1.5
24	914.4		812.8	749.3	692.15	58.7	54.1	177.7	609.6	696	16.66	11.13	41.3	24	R77	1.5
26	971.6		876.3	809.8	749.3	58.7	54.5	195.3	660.4	714.4	19.84	12.7	44.5	28	R93	1.5
28	1035.1		939.8	860.6	800.1	58.8	55	208	711.2	765.2	19.84	12.7	44.5	28	R94	1.5
30	1092.2		997	917.4	857.25	58.9	55.5	220.7	762	817.4	19.84	12.7	47.6	28	R95	1.5
32	1149.4		1054.1	984.3	914.4	59	56	235	812.8	871.7	23.01	14.27	50.8	28	R96	1.5
34	1206.5		1104.9	1035.1	965.2	59.1	56	244.7	863.6	925.9	23.01	14.27	50.8	28	R97	1.5
36	1270		1168.4	1092.2	1022.35	59.2	59	254.1	914.4	980.2	23.01	14.27	54	32	R98	1.5
38	1327.2		1219.2	1098.6	1028.7	59.3	59.2	250.7	965.2	1034.4	19.84	12.7	54	32		1.5
40	1384.3		1276.4	1172.4	1066.8	59.4	59.3	261.6	1016	1088.9	19.84	12.7	54	36		1.5
42	1447.8		1339.9	1227.8	1117.6	59.5	62.2	273.6	1066.8	1143.1	19.84	12.7	54	36		1.5
44	1505		1397	1285.2	1193.8	59.6	65	283.7	1117.6	1197.4	19.84	12.7	54	36		1.5
46	1562.1		1454.2	1340.1	1231.9	59.7	66.3	293.6	1168.4	1251.6	19.84	12.7	54	40		1.5
48	1651		1543.1	1395.6	1282.7	59.8	73.4	305.8	1219.2	1305.9	19.84	12.7	54	40		1.5

CLASS 600 FLANGES

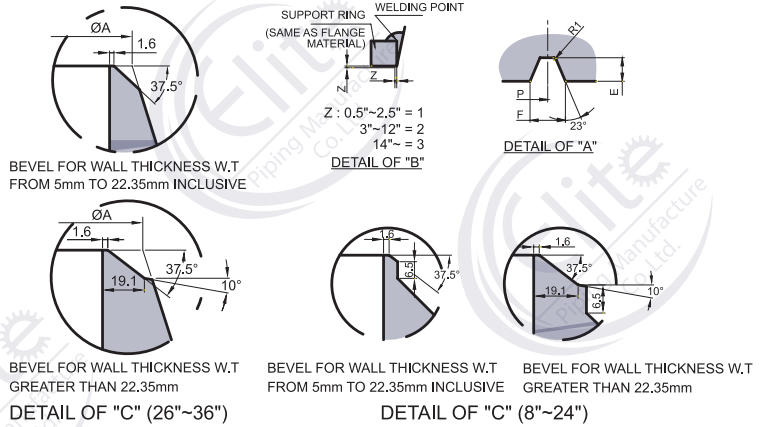
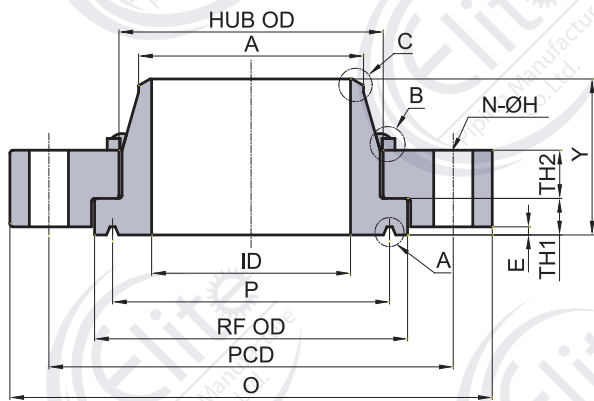

Unit : mm

Nominal Dia. Of Flange	Sectional Dimensions of flange															
	Outside Dia. Of Flange O	Dia of Bolt Circle PCD	Dia. of Raised Face RF OD	P	TH1	TH2	Y	Dia. of Hub		Radius R	F	E	Hole Dia H	Number of Bolt Holes N	RING NO	R1
								A	HUB OD							
8	419.1	349.3	301.8	269.88	27.6	34.5	134.9	219.1	241.3	3	11.91	7.92	31.8	12	49	0.8
10	508	431.8	355.6	323.85	33.2	41	147.6	273.1	301.6	6	11.91	7.92	34.9	16	53	0.8
12	558.8	489	412.8	381	36.3	44.2	153.9	323.9	358.8	6	11.91	7.92	34.9	20	57	0.8
14	603.3	527.1	457.2	419.1	38.8	45.9	163.6	355.6	396.9	6	11.91	7.92	38.1	20	61	0.8
16	685.8	603.3	508	469.9	42.2	52.6	185.7	406.4	451.3	6	11.91	7.92	41.3	20	65	0.8
18	743	654.1	574.5	533.4	47.8	52.9	190.5	457.2	515.1	6	11.91	7.92	44.5	20	69	0.8
20	812.8	723.9	635	584.2	51.4	59.6	218.9	508	563.4	6	13.49	9.53	44.5	24	73	1.5
22	870	777.7	685.8	635	54.7	63	238.3	558.8	615.6	6	15.09	11.13	47.6	24	81	1.5
24	939.8	838.2	749.3	692.15	59.2	65.3	246.1	609.6	675.4	6	16.66	11.13	50.8	24	77	1.5
26	1016	914.4	809.8	749.3	69.1	70.7	273.1	660.4	731.4	13	19.84	12.7	50.8	28	93	1.5
28	1073.2	965.2	860.6	800.1	70.3	72.1	282.4	711.2	787.5	13	19.84	12.7	54	28	94	1.5
30	1130.3	1022.4	917.4	857.25	74.8	76.1	292.1	762	838.1	13	19.84	12.7	54	28	95	1.5
32	1193.8	1079.5	984.3	914.4	60.3	82.2	309.6	812.8	889.6	13	23.01	14.27	60.3	28	96	1.5
34	1244.6	1130.3	1035.1	965.2	84.1	83.2	325.4	863.6	938.8	13	23.01	14.27	60.3	28	97	1.5
36	1314.5	1193.8	1092.2	1022.35	89.9	89.2	335	914.4	987.8	13	23.01	14.27	66.7	28	98	1.5

CLASS 900 FLANGES

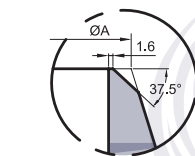
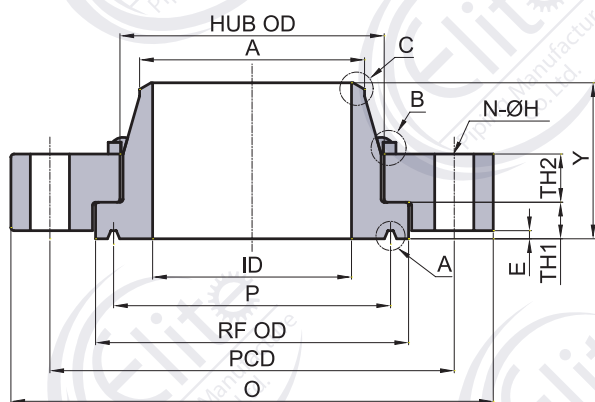

BEVEL FOR WALL THICKNESS W.T. FROM 5mm TO 22.35mm INCLUSIVE

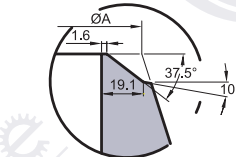

BEVEL FOR WALL THICKNESS W.T. GREATER THAN 22.35mm
DETAIL OF "C" (26"~36")

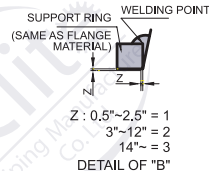

DETAIL OF "B"

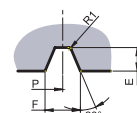

DETAIL OF "A"

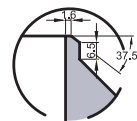

BEVEL FOR WALL THICKNESS W.T. FROM 5mm TO 22.35mm INCLUSIVE

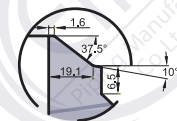

BEVEL FOR WALL THICKNESS W.T. GREATER THAN 22.35mm
DETAIL OF "C" (8"~24")

Unit : mm

Nominal Dia. Of Flange	Outside Dia. Of Flange O	Sectional Dimensions of flange														
		Dia of Bolt Circle PCD	Dia.of Raised Face RF OD	P	TH1	TH2	Y	Dia.of Hub		Radius R	F	E	Hole Dia H	Number of Bolt Holes N	RING NO	R1
								A	HUB OD							
8	470	394	305	269.88	35.6	47	152	219.1	257.5	6	11.91	7.92	38.1	12	49	0.8
10	545	470	401	323.85	46.6	49.7	184	273.1	325.7	6	11.91	7.92	38.1	16	53	0.8
12	610	533	452	381	53.1	57.4	192	323.9	373.9	6	11.91	7.92	38.1	20	57	0.8
14	640	559	486	419.1	59.1	60.7	217	355.6	404.0	6	16.66	11.13	41.3	20	62	1.5
16	705	616	533	469.9	69.1	67.9	236	406.4	447.0	6	16.66	11.13	44.5	20	66	1.5
18	785	686	603	533.4	72.2	73.1	268	457.2	511.9	6	19.84	12.7	50.8	20	70	1.5
20	855	749	664	584.2	77.6	77.1	286	508	569.5	6	19.84	12.7	54	20	74	1.5
24	1040	902	803	692.15	88.7	88.5	353	609.6	701.5	6	26.97	15.88	66.7	20	78	2.3
26	1085	952	848	749.3	99.1	97.6	357	660.4	734.6	13	30.18	17.48	73	20	100	2.3
28	1170	1022	911	800.1	105	103.3	376	711.2	794.2	13	33.32	17.48	79.4	20	101	2.3
30	1230	1086	975	857.25	110	107	399	762	853.9	13	33.32	17.48	79.4	20	102	2.3
32	1315	1156	1038	914.4	115.1	112.5	418	812.8	913.6	13	33.32	17.48	85.7	20	103	2.3
34	1395	1226	1102	965.2	121.4	118.3	459	863.6	972.8	13	36.53	20.62	92.1	20	104	2.3
36	1460	1289	1165	1022.35	126.1	122	459	914.4	1032.5	13	36.53	20.62	92.1	20	105	2.3

CLASS 1500 FLANGES

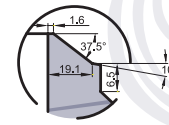
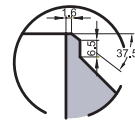
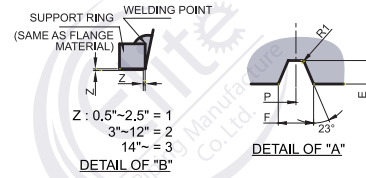
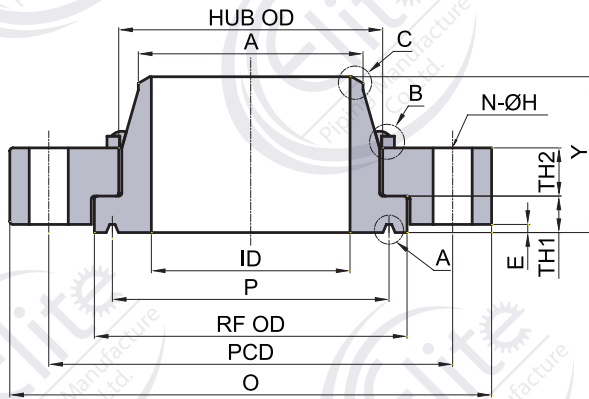

BEVEL FOR WALL THICKNESS W.T. FROM 5mm TO 22.35mm INCLUSIVE
 BEVEL FOR WALL THICKNESS W.T. GREATER THAN 22.35mm
 DETAIL OF "C"

Unit : mm

Nominal Dia. Of Flange	Outside Dia. Of Flange O	Sectional Dimensions of flange														
		Dia of Bolt Circle PCD	Dia. of Raised Face RF OD	P	TH1	TH2	Y	Dia. of Hub		Radius R	F	E	Hole Dia H	Number of Bolt Holes N	RING NO	R1
								A	HUB OD							
8	483	394	308	269.88	60.5	66.6	197	219.1	243.8	6	16.66	11.13	44.5	12	50	1.5
10	585	483	373	323.85	71.2	78.3	233	273.1	303.6	6	16.66	11.13	50.8	12	54	1.5
12	675	572	486	381	82.1	82.1	282	323.9	386.0	6	23.01	14.27	54	16	58	1.5
14	750	635	543	419.1	89.6	88.3	311	355.6	438.9	6	26.97	15.88	60.3	16	63	2.3
16	825	705	606	469.9	99.8	96.7	344	406.4	496.1	6	30.18	17.48	66.7	16	67	2.3
18	915	775	670	533.4	110.4	107.3	373	457.2	545.9	6	30.18	17.48	73	16	71	2.3
20	985	832	721	584.2	121.2	117.1	402	508	587.7	6	33.32	17.48	79.4	16	75	2.3
24	1170	991	867	692.15	140.1	131.6	483	609.6	723.0	6	36.53	20.62	92.1	16	79	2.3